

Codo Junta Hidráulica

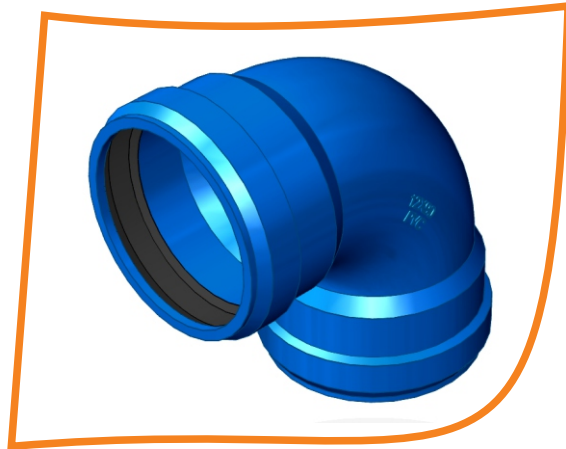

Especificaciones:

- Cuerpo: Hierro Nodular ASTM A - 536
Presión de trabajo: 250 psi
- Acabado: Pintura Epóxica azul
- Empaque : NBR - SBR
- Presentaciones Disponibles:
90° - 45° - 22.5° - 11.25°
- Norma AWWA C153

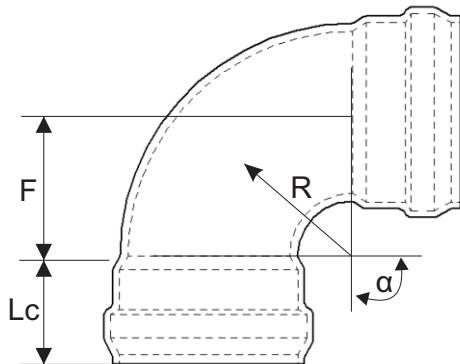

ENSIONES GENERALES

(mm y grados)



Diam Nominal	$\alpha = 90^\circ$		$\alpha = 45^\circ$		$\alpha = 22,5^\circ$		$\alpha = 11,25^\circ$	
	F	R	F	R	F	R	F	R
3	89.8	89.8	38.1	92.0	25.4	127.6	25.4	257.6
4	102.5	102.5	50.8	122.6	38.1	191.5	31.57	322.0
6	127.9	127.9	76.2	183.9	50.8	255.3	38.1	386.4
8	166	166	88.9	214.6	63.5	319.2	44.4	450.9
10	191.4	191.4	114.3	275.9	76.2	383.0	50.8	515.3
12	229.5	229.5	139.7	337.2	88.9	446.9	57.1	579.7
14	292.2	292.2	127	306.6	95.25	478.7	63.5	644.1
16	317.5	317.5	139.7	337.2	95.25	478.7	63.5	644.1

puede revisar si el documento esta actualizado en
www.ideacolombia.com/listadodoc.pdf