

CO-DC-41 V6
F. ACT. 23/062020

Tee Extremo Liso

Especificaciones:

- Cuerpo: Hierro Fundido ASTM A-126 Clase B
Presión de trabajo: 150 psi
- Cuerpo: Hierro Nodular ASTM A-536
Presión de trabajo: 250 psi
- Acabado: Pintura Epóxica azul
- Norma AWWA C153
- Extremo liso

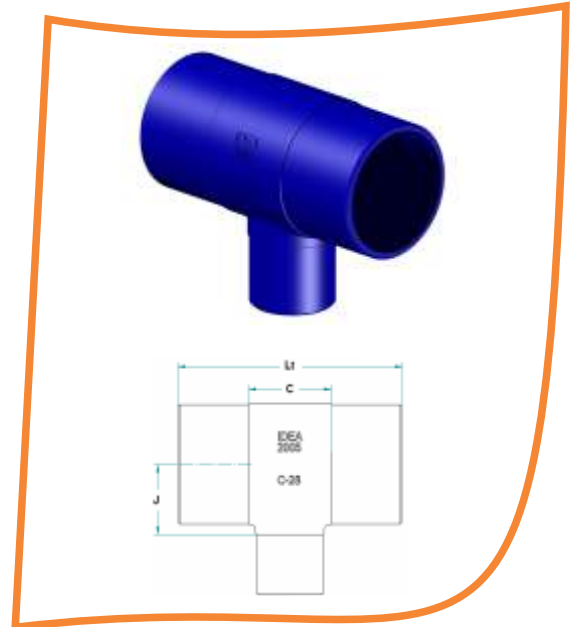

DIMENSIONES GENERALES (mm)

DN pulg	Φ E mm	ESPIGO	
		PVC	J
2	60	90	55
3	89	110	76
4	114	120	101
6	168	140	127
8	219	160	165
10	273	180	190
12	323	200	222
14	355	215	260
16	406	235	290
18	457	255	315
20	508	275	355
24	610	300	410

C											
2	3	4	6	8	10	12	14	16	18	20	24
110											
110	152										
110	178	202									
110	178	202	254								
110	190	202	254	330							
	190	202	254	330	380						
	190	202	254	330	380	440					
		280	330	380	430	480	520				
			330	380	430	480	520	580			
			330	380	430	480	520	580	630		
			330	406	456	500	560	608	660	710	
			330	406	456	500	560	608	660	710	820

Diam Nominal		Longitud total ESPIGO PVC											
DN Pulg	Φ E mm	2	3	4	6	8	10	12	14	16	18	20	24
2	60	290											
3	89	330	372										
4	114	350	418	442									
6	168	390	458	482	534								
8	219	430	510	522	574	650							
10	273		550	562	614	690	740						
12	323		590	602	654	730	780	840					
14	355			710	760	810	860	910	950				
16	406				800	850	900	950	990	1050			
18	457				840	890	940	990	1030	1090	1140		
20	508				880	956	1006	1050	1110	1158	1210	1260	
24	610				930	1006	1056	1100	1160	1208	1260	1310	1420



puede revisar si el documento esta actualizado en
www.ideacolombia.com/listadodoc.pdf

www.ideacolombia.com
negocios@ideacolombia.com
Calle 45 N° 16-35 Bucaramanga - Colombia
PBX: 57 - 7- 6522037

